

HOW TO CLEAN THE ORIFICE.

A blocked orifice is indicated by a significant decrease in fuel flow or erratic flame. To clear, follow these instructions CAREFULLY.

1. Turn off control valve.
2. Be sure torch is cool.
3. Disconnect torch from the fuel cylinder.
4. Remove burner head with a wrench.
5. Remove orifice and hold it in a wrench (reversed) position tightly against the end of the tube.
6. Quickly open and close control valve twice to permit bursts of propane to dislodge particles blocking hole. NEVER USE A NEEDLE, WIRE OR FOREIGN OBJECT TO CLEAR ORIFICE HOLE.



YOUR PROPANE TORCH COMES EQUIPPED WITH A PENCIL POINT BURNER TIP FOR A SHARP POINTED FLAME OR A UTILITY TIP FOR HEAVY DUTY JOBS.

IMPORTANT: PENCIL TIP ORIFICE AND UTILITY TIP ORIFICE ARE NOT INTERCHANGEABLE! THEY CAN ONLY BE USED WITH THEIR RESPECTIVE TIPS.

INSTRUCTIONS FOR CHANGING BURNER TIP AND ORIFICE

1. Disconnect torch from the fuel cylinder.
2. Clamp angle tube in a vise to prevent the angle tube from being twisted at its connection in the valve. Such a loose connection will result in a large leak of fuel from the valve when the torch is turned 'on'.
3. Unscrew old burner tip with a wrench and remove orifice block from end of tube.
4. Place new orifice in tube and screw on new burner tip. The new orifice must be placed in the tube in the same position as the old orifice. Failure to do so will lead to an excessive amount of fuel being emitted from the tip when the torch is turned 'on'.
5. When screwing burner tip onto the angle tube, tighten just enough to prevent leakage. Over tightening could damage the orifice block and/or angle tube could result in a dangerous fuel leak when the torch is turned 'on'.

Warning: Byproducts of the combustion of the fuel used by this product contains chemicals known to the State of California to cause cancer or reproductive harm.

MAGNA INDUSTRIES, INC.
P.O. Box 734
Lakewood, Ohio 44107

ALWAYS USE YOUR TORCH IN A WELL VENTILATED AREA

CARE AND OPERATING INSTRUCTIONS
FOR YOUR MAGNA PROPANE TORCH

PROPANE TORCH

Please Read Carefully Before Using.

**DANGER: CONTENTS EXTREMELY FLAMMABLE
AND UNDER PRESSURE.**

KEEP OUT OF THE REACH OF CHILDREN.

DO NOT Store at temperatures over 120°. Keep away from heat and flame.

DO NOT store in room used for habitation.

Read cautions on individual propane containers.

TORCH SAFETY

1. Before attaching torch to fuel tank. Check valve control to be sure it is fully closed by turning knob to the right.
2. Thread fuel tank into the torch. Turn to the right until they are seated hand tight. Do not use wrench to tighten. HAND TIGHTEN ONLY. DO NOT ATTACH OR DETACH TORCH WHERE ACCIDENTALLY RELEASED PROPANE CAN BE IGNITED BY OPEN FLAMES. Crossed threads may result in the sudden escape of extremely flammable fuel.
3. Check all joints and couplings periodically to insure against loose connections. With valve open, without lighting, test all connections with soapy water. If bubbles appear gas is leaking. NEVER USE A FLAME TO CHECK LEAKS.

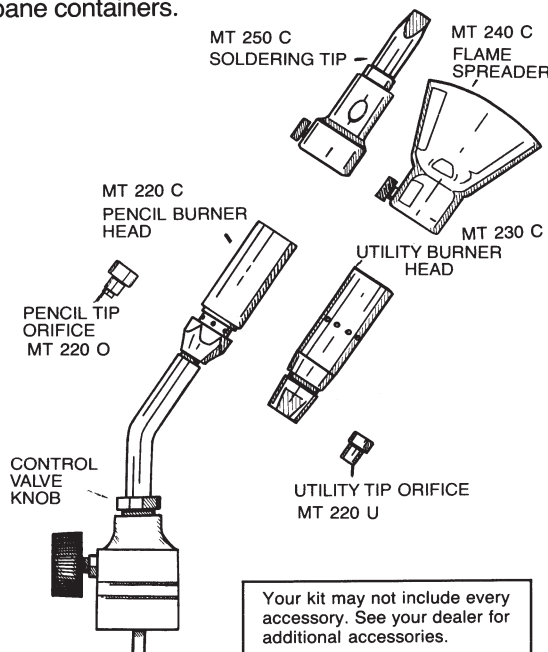

TORCH LIGHTING INSTRUCTIONS

1. Open valve ¼ turn (turn to left) and light with match or spark lighter.
2. Turn valve knob to adjust flame as desired.
3. BEFORE USING THIS TORCH IN INVERTED POSITION, ALLOW A TWO MINUTE WARM UP. A large flame may be produced by a cold torch which is tipped towards a horizontal or inverted position.
4. Shut off the torch by turning valve knob to the right. The flame may continue to burn for a few seconds after the valve has been turned to the 'off' position. If flame does not go out, blow it out and disconnect the torch from the fuel cylinder.
5. Remove fuel tank from torch.

DO NOT STORE WITH TORCH ATTACHED TO FUEL TANK.